

## INSTALLATION GUIDE - SERIES 001, 002, 003, 004, 006, & 007

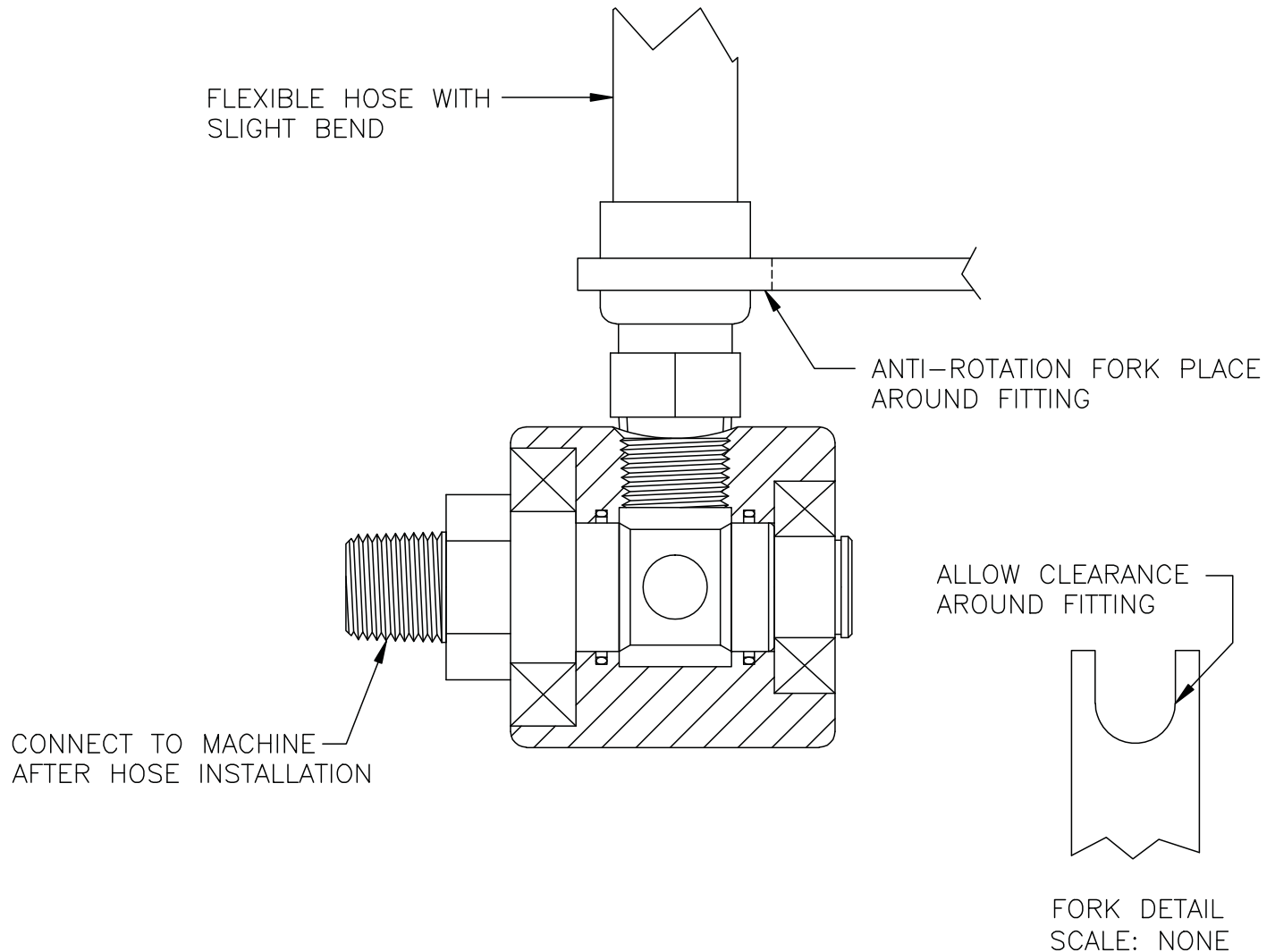

### PROPER USE AND MOUNTING INSTRUCTIONS

1. Connect fittings to housing prior to threading union to machine.
  - Do not use rigid piping as this will compromise the life of the union.
  - The hose should be flexible and have a slight bend.
    - Extreme bends can reduce the flexibility of the hose.
  - The rubber hose selected should be able to safely handle the working pressure.
  - The hose should be properly supported & should not side load the union.
2. Connect male thread to machine using Teflon tape or pipe sealant.
3. Attach your preferred method of anti-rotation, such as a fork around the fitting. Anti-rotation must allow the union to find its center. Do not hard mount both the rotor and housing of the union.



**ROTARY**  
SYSTEMS INC